

Cast Steel Gate Valves



Figure 30-OF-U

Class 300 • Outside Screw & Yoke • Flexible Wedge Disc

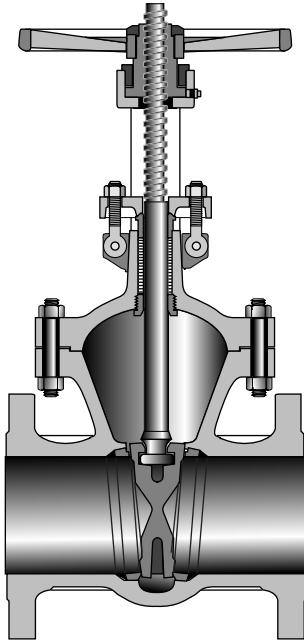

Figure 30-OF-U
Flanged

Size Range:
2 through 24 inches

Pressure Temperature Rating
Carbon Steel
ASTM A216 Grade WCB
740 psi @ -20°F to 100°F

Materials of Construction

Description	Material
Body	ASTM A216 WCB
Bonnet	ASTM A216 WCB
Seat Rings	ASTM A105 + AWS CoCr-A
Wedge	ASTM A216 WCB + 13% Cr
Stem	ASTM A182 F6a
Packing	Graphite
Bonnet Gasket	Soft Steel + Flexible Graphite
Back Seat	ASTM A276 410
Yoke Sleeve	ASTM A439 D2
Retaining Nut	ASTM A216 WCB
Gland	ASTM A276 410
Gland Flange	ASTM A216 WCB
Eye Bolt	ASTM A307 B
Eye Bolt Nuts	ASTM A194 2H
Pins	AISI C1045
Bonnet Studs	ASTM A193 B7
Bonnet Nuts	ASTM A194 2H
Handwheel	Ductile Iron
Handwheel Nut	AISI C1020
I.D. Tags	ASTM A276 304
I.D. Pins	ASTM A276 304
Spacer	ASTM A276 410
Grease Fittings	Carbon Steel

Industry Standards

Steel Valves	ASME B16.34
Face-to-Face/End-to-End	ASME B16.10
Flange Dimensions	ASME B16.5
Basic Design	API 600
Testing	API 598

Dimensions and Weights

Valve Size	Weight (pounds)	Dimensions (inches)		
		A	B (open)	C
2	48	8.5	16.9	7.9
2½	79	9.5	19.9	9.8
3	115	11.1	21.4	9.8
4	166	12.0	24.8	9.8
5	276	11.0	28.5	15.7
6	324	15.9	32.5	15.7
8	483	16.5	39.7	15.7
10	776	18.0	48.8	17.7
12	1040	19.8	57.9	19.7
14	1530	30.0	63.0	22.0
16	2380	33.0	70.5	25.2
18	2722	36.0	77.1	26.8
20	3648	39.0	85.8	29.9
24	5510	45.0	104.5	36.0

